

www.synex.co.in



High

SPEED
ACCURACY
RIGIDITY



HIGH SPEED
CNC MACHINE
TURNING CENTER

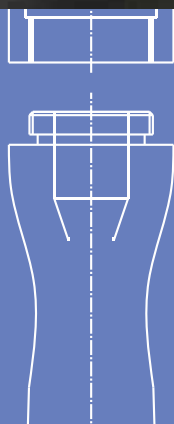

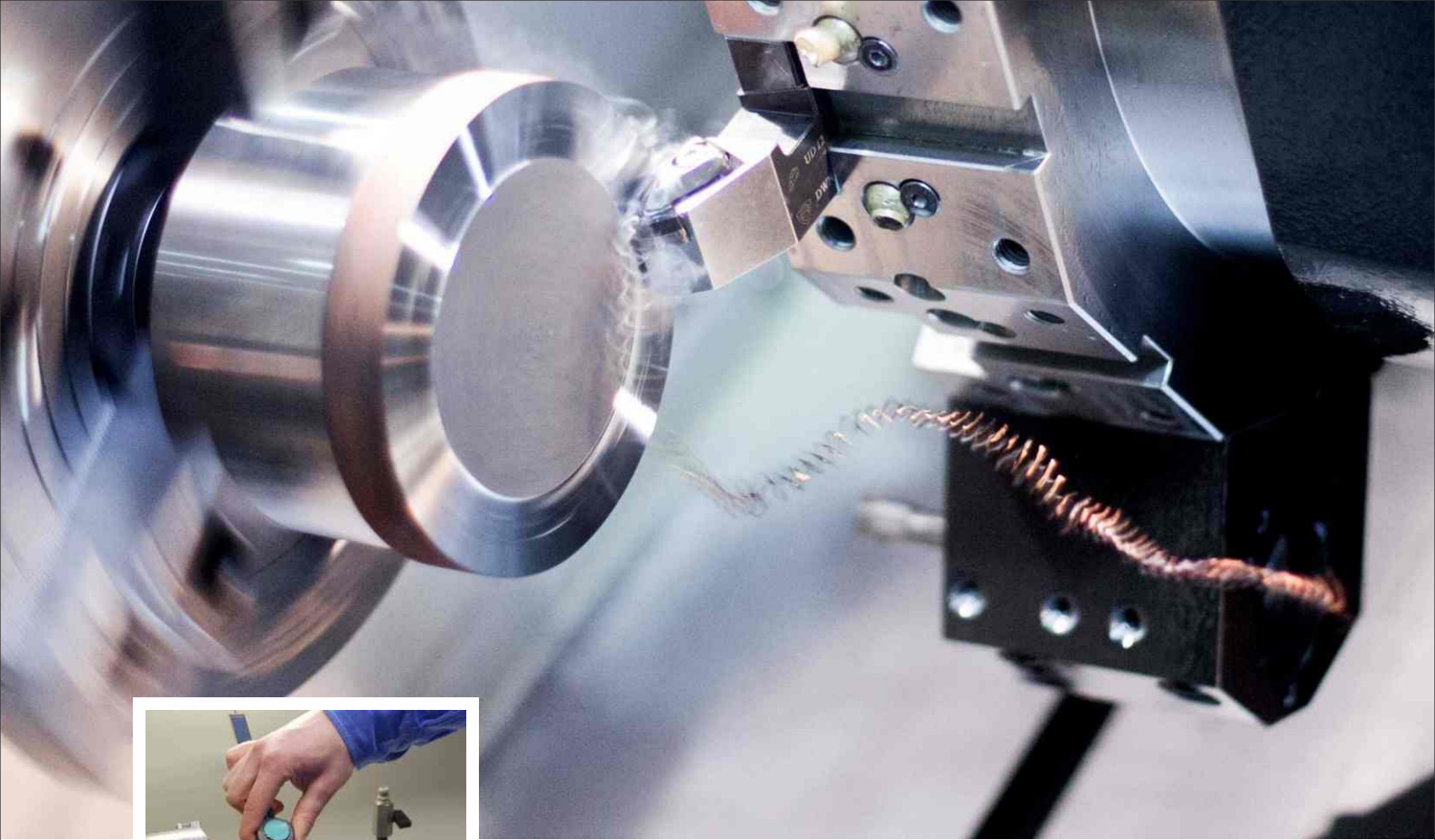

ABOUT COMPANY

Synex cnc located in Ahmedabad Gujarat India. Synex cnc aims to achieve total customer satisfaction in our all type of products by increasing product value through implementation of continues improvement in product process and cost. Synex cnc is one of the most being quality conscious company. We have been job working to produce quality product throughout our inspection. We tested our workshop throughout by the quality controller and our instrument before use further. Our organization has set up huge infrastructure which is equipped with the modern machinery and modern instrument and tools. We manage strictly monitored. We are delighted to have team of highly dedicated and highly skill team of professional who process excellent industrial knowledge and more experience in engineering field under the guidance products are stringently tested on various parameters. We are also capable of to do the manufacture or job working as per your requirement and as per your drawing specification.

Product Component

Ejector vacuum Nozzle 50 mm length to 500 mm length (Single piece)
Sub part of pneumatic control valve. (Ex. Seat Cage, Plug & Cylinder, Bonnet etc.)
Component of Turbine bypass valve for HP-IP-LP System.
Component of Water injector Control Valve.
Diffuser Nozzle.
Reducing Valve.
Component of desuperheater.
And Many More Parts.



Actual Sample

Material Use

Stainless Steel
Mild Steel
Copper
Bras
Aluminum
Also As Per Requirement

Actual Sample Image

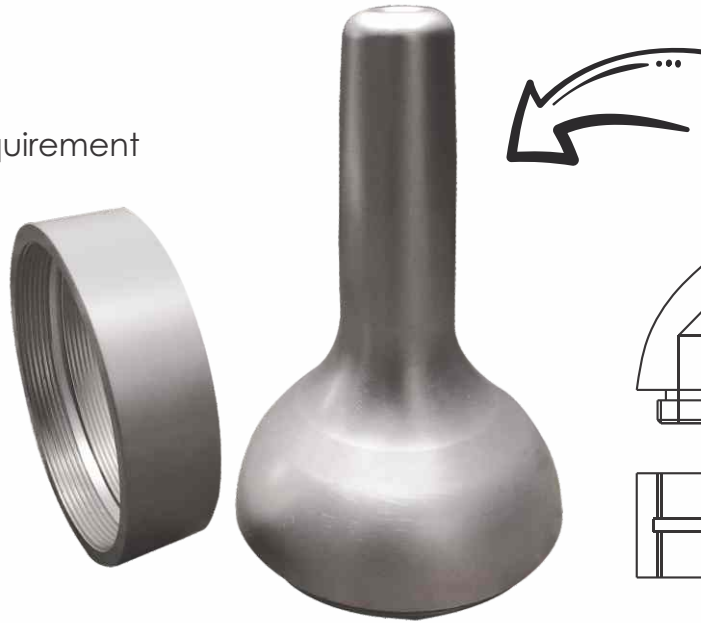

Drawing

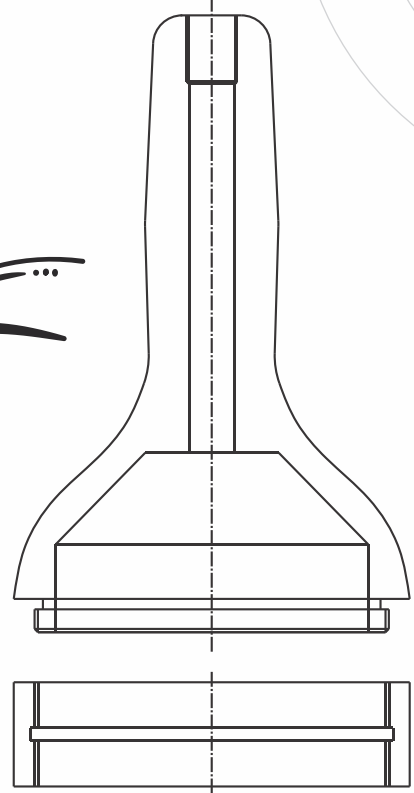



www.synex.co.in

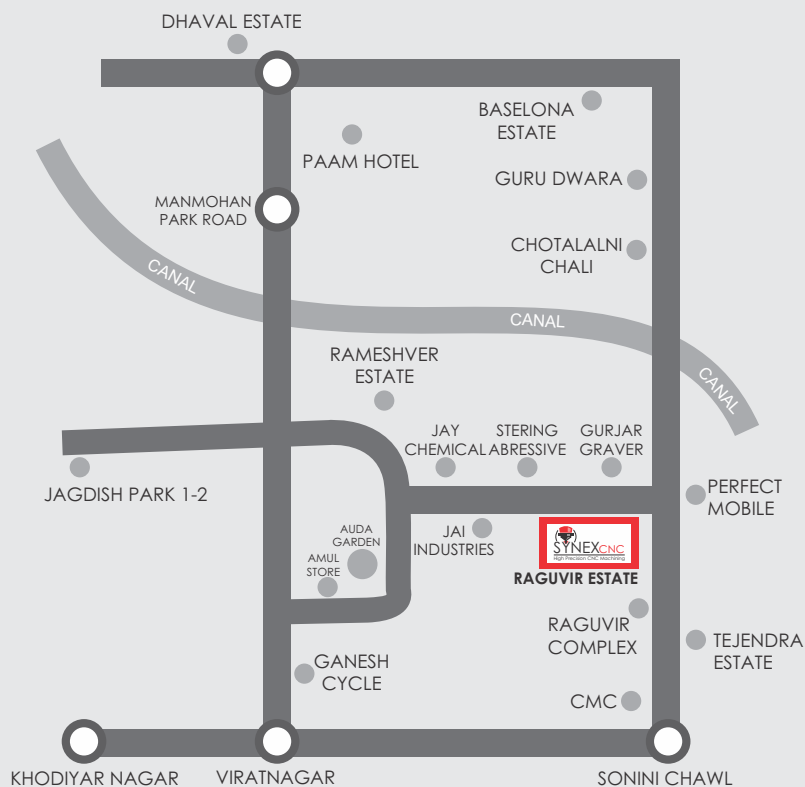

SYNEX CNC

48, Raghuvir Industrial Estate, Panchal Engineering Compound,
B/h. Raghuvir Complex, Odhav, Ahmedabad- 382415. Guj. (India)

E-mail: synexcnc@gmail.com

Mo. : 96015 00501